

- Single-phase and three-phase full voltage starters
- Solid-state overload relay
- Non-combination type
- Standard width and extra wide enclosures
- UL listed file #E14900
- CSA certified file #LR6535

Coil Table

60Hz Voltage	Letter
24 Separate Control	J
120 Separate Control	F
110-120/220-240	A
200-208	D
220-240	G
277	L
220-240/440-480	C
440-480	H
575-600	E

Standard Width Enclosure, 3-Phase, 3-Pole

Max Hp Rating				NEMA Size (1/2 Size)	Overload Relay Amp Range	Enclosure Type				
Motor Voltage						1	4/4X S.S.	4X Fg.	7/9/3/4	3/3R/12
200	230	460	575			Catalog Number				
1/6	1/6	1/3	1/2	00	0.25-1	14BUA32B*	Use Size 0	Use Size 0	Use Size 0	Use Size 0
1/2	3/4	1 1/2	2	00	0.75-3.4	14BUB32B*	Use Size 0	Use Size 0	Use Size 0	Use Size 0
1 1/2	1 1/2	2	—	00	3-12	14BUC32B*	Use Size 0	Use Size 0	Use Size 0	Use Size 0
1/6	1/6	1/3	1/2	0	0.25-1	14CUA32B*	14CUA32W*	14CUA32F*	14CUA32H*	14CUA320*
1/2	3/4	1 1/2	2	0	0.75-3.4	14CUB32B*	14CUB32W*	14CUB32F*	14CUB32H*	14CUB320*
2	2	5	5	0	3-12	14CUC32B*	14CUC32W*	14CUC32F*	14CUC32H*	14CUC320*
3	3	—	—	0	5.5-22	14CUD32B*	14CUD32W*	14CUD32F*	14CUD32H*	14CUD320*
1/6	1/6	1/3	1/2	1	0.25-1	14DUA32B*	14DUA32W*	14DUA32F*	14DUA32H*	14DUA320*
1/2	3/4	1 1/2	2	1	0.75-3.4	14DUB32B*	14DUB32W*	14DUB32F*	14DUB32H*	14DUB320*
2	2	5	5	1	3-12	14DUC32B*	14DUC32W*	14DUC32F*	14DUC32H*	14DUC320*
3	3	10	10	1	5.5-22	14DUD32B*	14DUD32W*	14DUD32F*	14DUD32H*	14DUD320*
7 1/2	7 1/2	—	—	1	10-40	14DUE32B*	14DUE32W*	14DUE32F*	14DUE32H*	14DUE320*
10	10	15	15	(1 3/4)	10-40	14EUE32B*	14EUE32W*	14EUE32F*	14EUE32H*	14EUE320*
10	15	25	25	2	13-52	14FUF32B*	14FUF32W*	14FUF32F*	14FUF32H*	14FUF320*
15	20	30	30	(2 1/2)	25-100	14GUG32B*	14GUG32W*	14GUG32F*	14GUG32H*	14GUG320*
25	30	50	50	3	25-100	14HUG32B*	14HUG32W*	14HUG32F*	14HUG32H*	14HUG320*
30	40	75	75	(3 1/2)	50-200	14IUH32B*	14IUH32W*	14IUH32F*	14IUH32H*	14IUH320*
40	50	100	100	4	50-200	14JUH32B*	14JUH32W*	14JUH32F*	14JUH32H*	14JUH320*
75	100	200	200	5 [A]	55-250	14LPU32B*	14LPU32E* [E]	—	14LPU32H*	14LPU320*
150	200	400	400	6 [A]	160-630	14MPX32B*	14MPX32E* [E]	—	—	14MPX320*
—	300	600	600	7 [A,B]	400-1220	14NUN32B*	14NUN32E* [E]	—	—	14NUN320*
—	450	900	900	8 [A,C]	400-1220	14PUN32B*	14PUN32E* [E]	—	—	14PUN320*

Replace the (*) with a letter from the coil table. Dual voltage coils are wired on high voltage unless specified on order.

[A] Dual voltage coils not available in size 5 - 8 starters.

[B] Available with only F and H coils.

[C] Available with only F coil.

[D] Coils E, H and L not available in single phase starters.

[E] Enclosure is Type 4 painted steel.

Max Hp Rating		NEMA Size (1/2 Size)	Overload Relay Amp Range	Enclosure Type				
Motor Voltage				1	4/4X S.S.	4X Fg.	7/9/3/4	3/3R/12
115	208 / 230			Catalog Number				
1/8	1/4	0	0.75-3.4	14CUB12B*	14CUB12W*	14CUB12F*	14CUB12H*	14CUB120*
1/4	1/2	0	3-12	14CUC12B*	14CUC12W*	14CUC12F*	14CUC12H*	14CUC120*
1	2	0	5.5-22	14CUD12B*	14CUD12W*	14CUD12F*	14CUD12H*	14CUD120*
1/8	1/4	1	0.75-3.4	14DUB12B*	14DUB12W*	14DUB12F*	14DUB12H*	14DUB120*
1/4	1/2	1	3-12	14DUC12B*	14DUC12W*	14DUC12F*	14DUC12H*	14DUC120*
1	2	1	5.5-22	14DUD12B*	14DUD12W*	14DUD12F*	14DUD12H*	14DUD120*

Extra Wide Enclosure, 3-Phase, 3-Pole

Max Hp Rating				NEMA Size (1/2 Size)	Overload Relay Amp Range	Enclosure Type			
Motor Voltage						1	4/4X S.S.	7/9/3/4	3/3R/12
200	230	460	575			Catalog Number			
1/6	1/6	1/3	1/2	00	0.25-1	14BUA82B*	Use Size 0	Use Size 0	Use Size 0
1/2	3/4	1 1/2	2	00	0.75-3.4	14BUB82B*	Use Size 0	Use Size 0	Use Size 0
1 1/2	1 1/2	2	—	00	3-12	14BUC82B*	Use Size 0	Use Size 0	Use Size 0
1/6	1/6	1/3	1/2	0	0.25-1	14CUA82B*	14CUA82W*	14CUA82H*	14CUA820*
1/2	3/4	1 1/2	2	0	0.75-3.4	14CUB82B*	14CUB82W*	14CUB82H*	14CUB820*
2	2	5	5	0	3-12	14CUC82B*	14CUC82W*	14CUC82H*	14CUC820*
3	3	—	—	0	5.5-22	14CUD82B*	14CUD82W*	14CUD82H*	14CUD820*
1/6	1/6	1/3	1/2	1	0.25-1	14DUA82B*	14DUA82W*	14DUA82H*	14DUA820*
1/2	3/4	1 1/2	2	1	0.75-3.4	14DUB82B*	14DUB82W*	14DUB82H*	14DUB820*
2	2	5	5	1	3-12	14DUC82B*	14DUC82W*	14DUC82H*	14DUC820*
3	3	10	10	1	5.5-22	14DUD82B*	14DUD82W*	14DUD82H*	14DUD820*
7 1/2	7 1/2	—	—	1	10-40	14DUE82B*	14DUE82W*	14DUE82H*	14DUE820*
10	10	15	15	(1 3/4)	10-40	14EUE82B*	14EUE82W*	14EUE82H*	14EUE820*
10	15	25	25	2	13-52	14FUF82B*	14FUF82W*	14FUF82H*	14FUF820*
15	20	30	30	(2 1/2)	25-100	14GUG82B*	14GUG82W*	14GUG82H*	14GUG820*
25	30	50	50	3	25-100	14HUG82B*	14HUG82W*	14HUG82H*	14HUG820*
30	40	75	75	(3 1/2)	50-200	14IUH82B*	14IUH82W*	14IUH82H*	14IUH820*

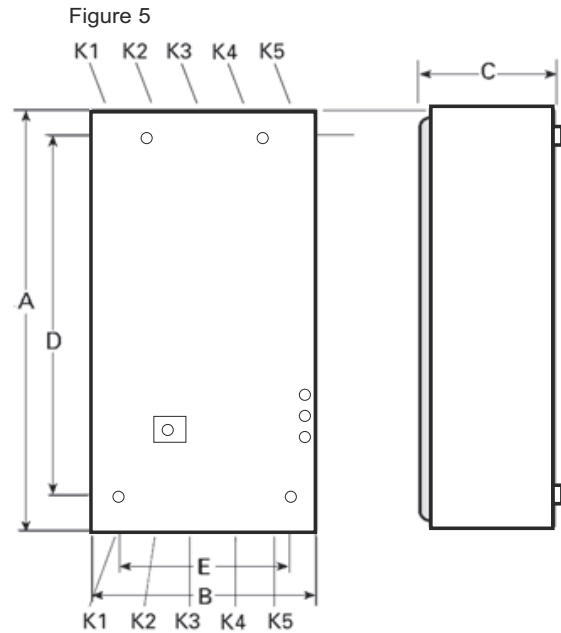
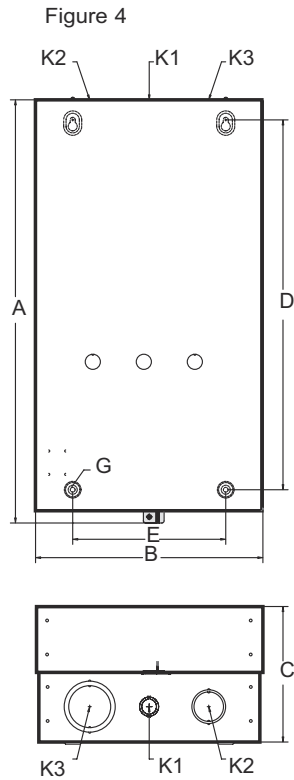
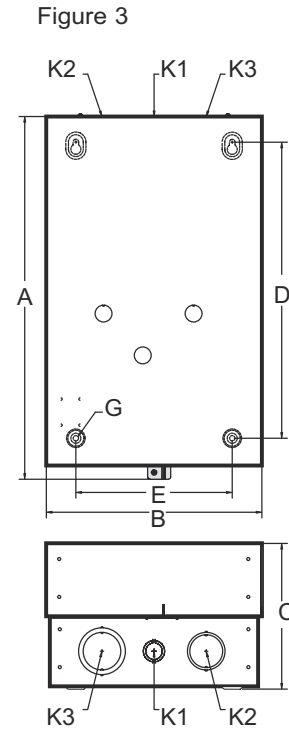
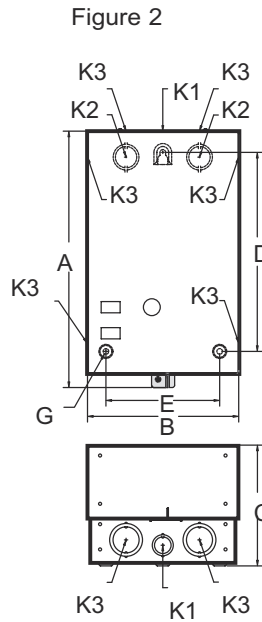
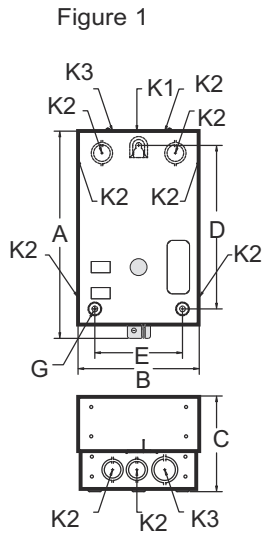

View is typical for bottom and top

Enclosure Type	Size	Fig. [2]	Outline Dimensions			Mounting			Conduit Size					Approx. Ship Wt Lbs
			A	B	C	D	E	G [1]	K1	K2	K3	K4	K5	
1 (Standard width for use with or without CPT)	00-1 3/4 (w/o CPT)	1	11.00	6.41	5.00	8.22	4.63	0.25	0.5	0.5-0.75	0.75-1	—	—	10
	2-2 1/2 (w/o CPT)	2	13.53	8.00	6.38	10.25	6.00	0.25	0.5-0.75	0.75-1	1-1.25	—	—	15
	3-3 1/2	3	19.13	11.38	7.69	15.63	8.25	0.25	0.5-0.75	1-1.25	1.5-2	—	—	26
	4	4	24.88	13.38	8.13	21.75	9.00	0.25	0.5-0.75	1.25-1.5	2-2.5	—	—	37
	5	5	40.00	20.00	11.00	37.63	15.25	0.25	2-3	1.25-1.5	0.5-0.75	1.25-1.5	2-3	135
1 (Extra wide for use with CPT)	6.7	5	48.00	20.00	12.50	45.19	10.00	0.25	2-2.5	1.25-1.5	0.5-0.75	1.25-1.5	2-2.5	150
	00-2 1/2	3	19.13	11.38	7.69	15.63	8.25	0.25	0.5-0.75	1-1.25	1.5-2	—	—	26
	3-3 1/2	4	24.88	13.38	8.13	21.75	9.00	0.25	0.5-0.75	1.25-1.5	2-2.5	—	—	37

[1] G designates mounting screw size.

[2] Enclosures shown in figures 1 - 4 have lift-off covers. Enclosures shown in figure 5 have hinged covers.

Dimensions are in inches.

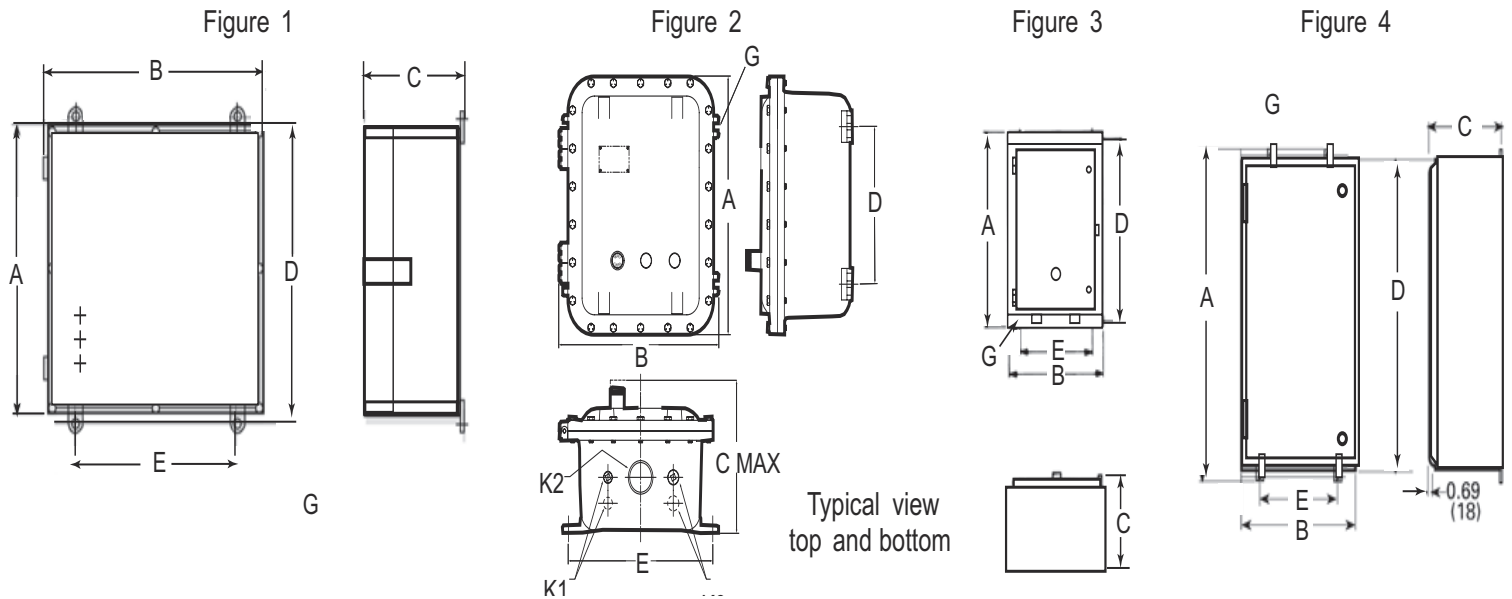

Enclosure Type	Size	Fig. [2]	Outline Dimensions			Mounting			Conduit Size			Approx. Ship Wt Lbs
			A	B	C	D	E	G [1]	K1	K2	K3	
4/4X Fg (Std width for use w/ or w/o CPT)	0-2 1/2	1	14.62	11.88	6.89	15.00	9.75	0.25	—	—	—	11
	3-4	1	23.78	23.78	6.89	24.13	21.25	0.25	—	—	—	28
7/9/3/4 (Standard width for use with or without CPT)	0-1 3/4 (w/o CPT)	2	15.25	10.69	10.00	8.50	9.13	0.375	0.5	1.5	0.75	33
	0-1 3/4 (w/ CPT)	2	17.75	14.69	10.38	10.63	13.25	0.375	0.5	2	0.75	60
	2-2 1/2	2	17.75	14.69	10.38	10.63	13.25	0.375	0.5	2	0.75	60
	3	2	17.75	14.69	10.38	10.63	13.25	0.375	0.5	2	0.75	60
	3 1/2 - 4	2	28.69	17.75	11.75	18.38	15.75	0.500	0.5	3	0.75	140
5	2	48.88	22.88	14.88	29.00	21.60	0.625	0.5	3	0.75	352	
7/9/3/4 (Extra wide for use with CPT)	2-2 1/2	2	17.75	14.69	10.38	10.63	13.25	0.375	0.5	2	0.75	60
12/3/3R (Standard width for use without CPT)	0-1 3/4	3	13.00	7.75	5.44	12.25	5.00	0.25	—	—	—	12
	2-2 1/2	3	16.00	8.13	6.06	15.25	5.00	0.25	—	—	—	18
	3-4	3	26.00	13.13	7.56	25.25	10.00	0.25	—	—	—	49
12/3/3R (Extra wide for use with CPT)	00-1 3/4	3	13.00	12.63	5.38	12.25	10.00	0.25	—	—	—	30
	2-2 1/2	3	16.00	13.25	6.13	15.25	11.00	0.25	—	—	—	33
	3-3 1/2	3	26.00	13.13	7.56	25.25	10.00	0.25	—	—	—	49
	4	3	29.06	23.19	9.25	27.56	20.00	0.375	—	—	—	64
	5	4	40.00	20.00	11.00	41.00	10.00	0.375	—	—	—	
6, 7	4	48.00	20.00	12.50	49.00	10.00	0.375	—	—	—		
4/4X Stainless Steel (Standard width for use without CPT)	0-1 3/4	3	13.00	7.75	5.44	12.25	5.00	0.25	—	—	—	18
	2-2 1/2	3	16.00	8.13	6.06	15.25	5.00	0.25	—	—	—	36
	3-4	3	26.00	13.13	7.56	25.25	10.00	0.25	—	—	—	67
4/4X Stainless Steel (Extra wide for use with CPT)	00-1 3/4	3	13.00	12.63	5.38	12.25	10.00	0.25	—	—	—	30
	2-2 1/2	3	16.00	13.25	6.13	15.25	11.00	0.25	—	—	—	33
	3-3 1/2	3	26.00	13.13	7.56	25.25	10.00	0.25	—	—	—	64
	4	3	29.06	23.19	9.25	27.56	20.00	0.31	—	—	—	67
	5 (Painted)	4	40.00	20.00	11.00	41.00	10.00	0.375	—	—	—	
	6, 7 (Painted)	4	48.00	20.00	12.50	49.00	10.00	0.375	—	—	—	

[1] G designates mounting screw size.

[2] Enclosures shown in figures 1-4 have hinged covers.

Dimensions are in inches.

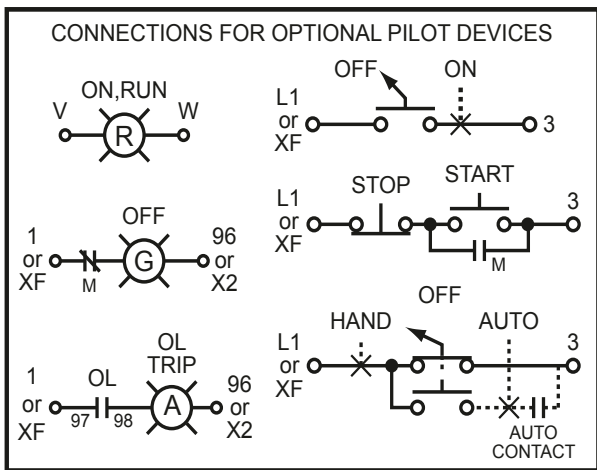
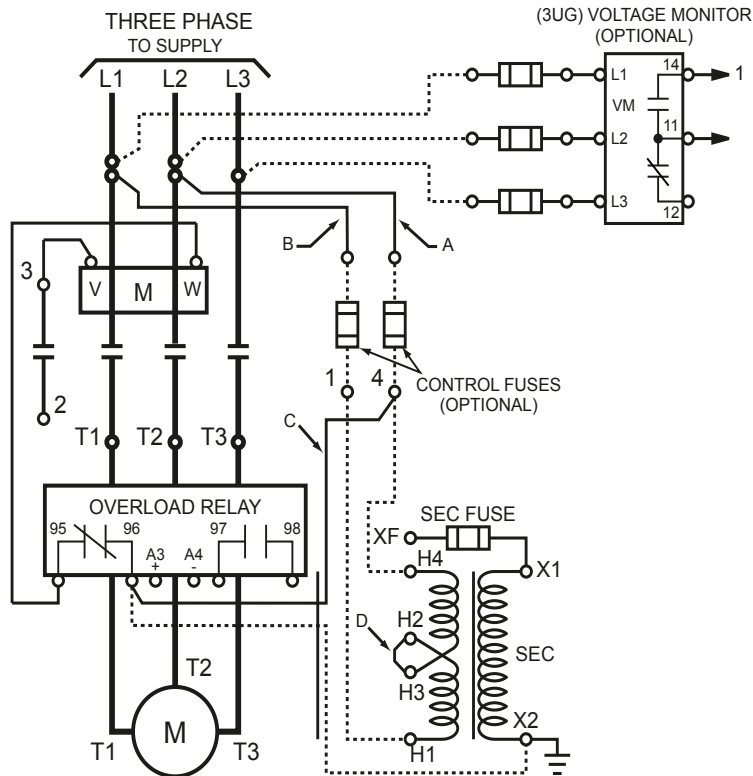
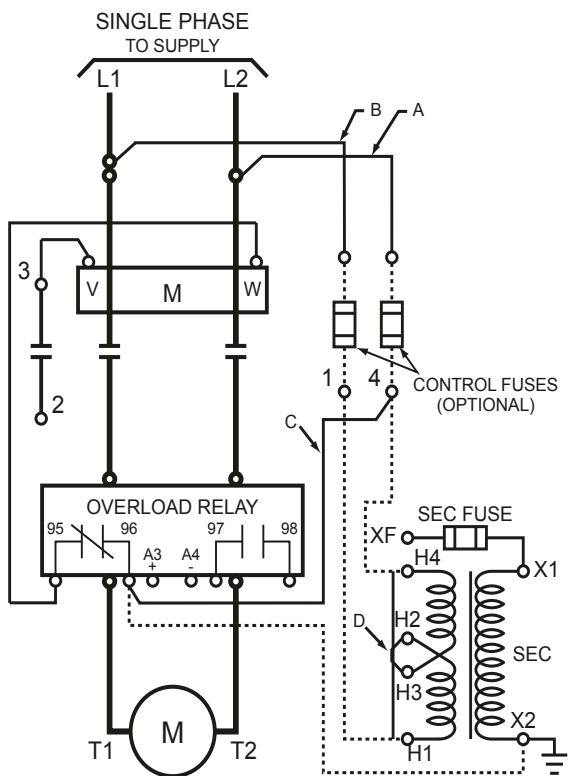

VOLTAGE MONITOR CONTACT IS TO PRECEDE CONTROL DEVICE CONNECTIONS. IF NO C.P.T. IS USED, LINE VOLTAGE IS NOT TO EXCEED 300VAC.

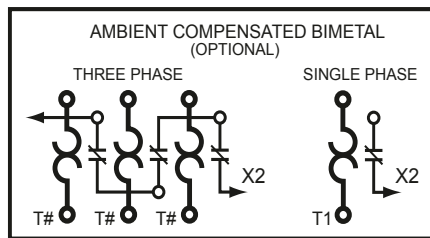

NOTES:

- 1) TRANSFORMER CONNECTIONS SHOWN ARE FOR HIGHER PRIMARY VOLTAGE. FOR LOWER VOLTAGE, REMOVE JUMPER "D" AND CONNECT "H1" TO "H3" AND "H2" TO "H4" ON TRANSFORMER. FOR CONNECTIONS OTHER THAN SHOWN, SEE TRANSFORMER NAMEPLATE.
- 2) FOR SEPARATE CONTROL VOLTAGE SOURCE, REMOVE JUMPERS "A" AND "B" AND CONNECT SOURCE TO CONTROL FUSE LINE TERMINALS.
- 3) WHEN FIELD ADDING A TRANSFORMER OR CHANGING TO A SEPERATE SOURCE, CHECK COIL VOLTAGE FOR COMPATIBILITY AND CHANGE COIL OR RECONNECT JUMPER IF NECESSARY.
- 4) REMOVE JUMPER "C" IF CONTROL TRANSFORMER IS USED.

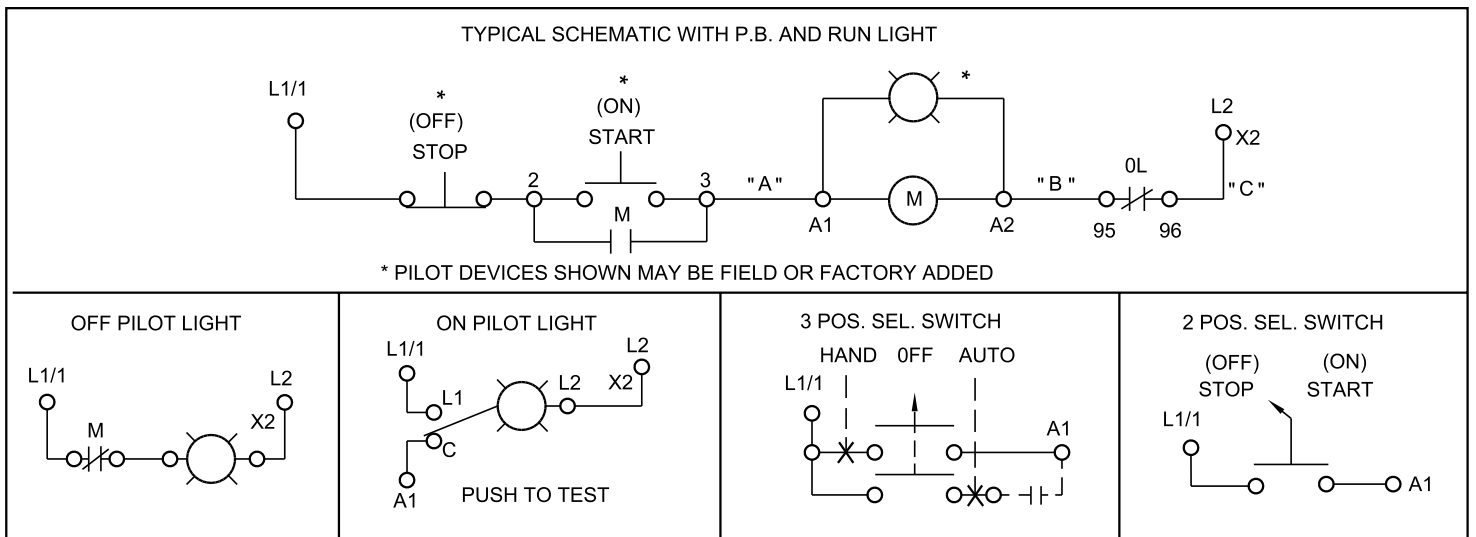
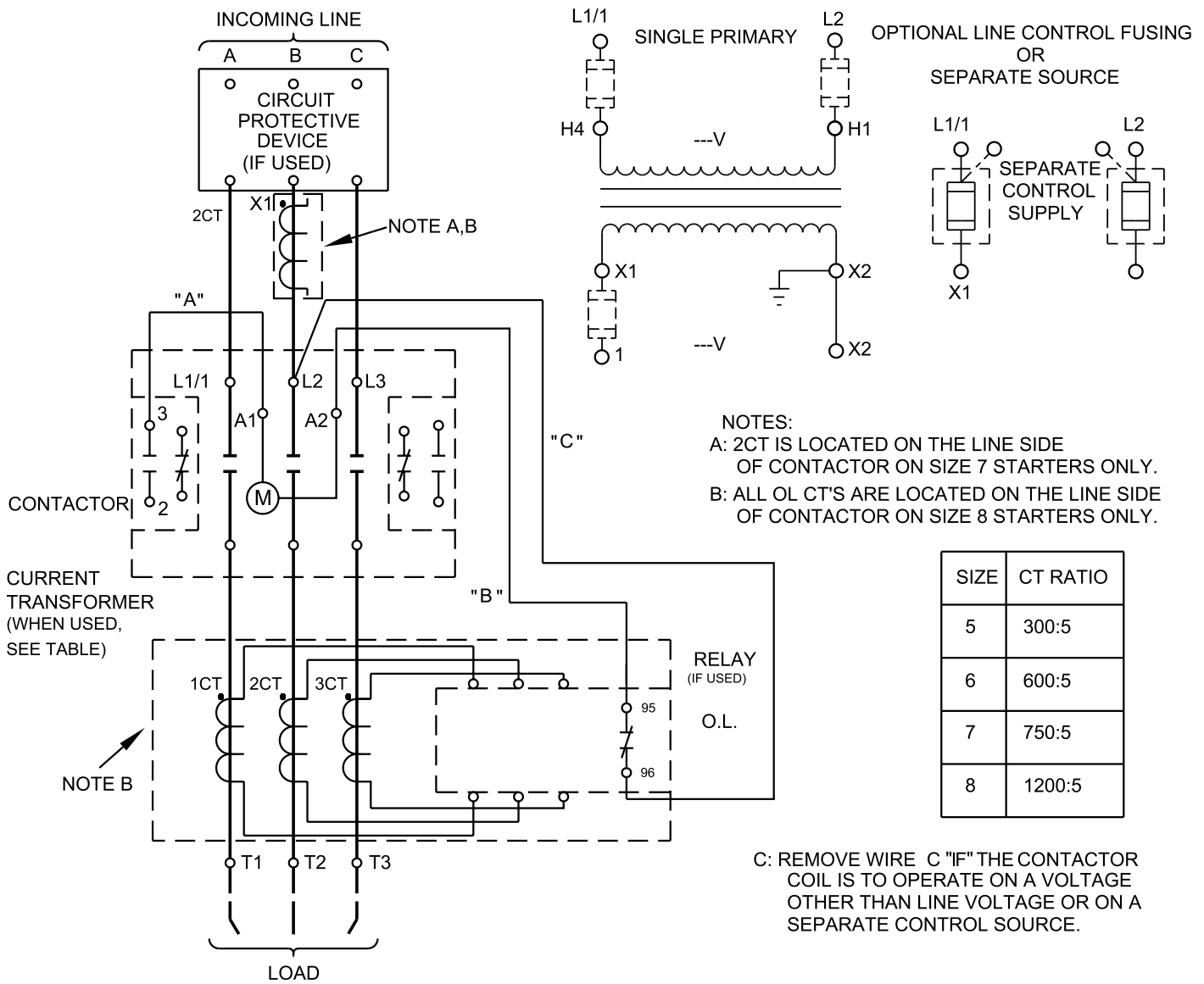

Common Accessories

Enclosure type	Description	Catalog No.
1 (with lift-off cover)	Start, Stop Push Buttons	49SBPB5
	Hand-Off-Auto Selector Switch	49SBSB1
	Off-On Selector Switch	49SBSB4
	Red/Green On/Run/Off* Pilot Light 24VAC	49SBLBJ
	Red/Green On/Run/Off* Pilot Light 120VAC	49SBLBF
	Red/Green On/Run/Off* Pilot Light 208/240/277VAC	49SBLBG
	Red/Green On/Run/Off* Pilot Light 480VAC	49SBLBH
1, 3/3R, 4/4X & 12 (with hinged cover)	Start, Stop Push Buttons	49SAP05
	Hand-Off-Auto Selector Switch	49SAS01
	Off-On Selector Switch	49SAS04
	Red On Pilot Light 24VAC	49SPL0BRJ
	Red On Pilot Light 120VAC	49SPL0BRF
	Red On Pilot Light 240VAC	49SPL0BRG
	Red On Pilot Light 480VAC	49SPL0BRH
	Green Off** Pilot Light 24VAC	49SPL0AGJ
	Green Off** Pilot Light 120VAC	49SPL0AGF
	Green Off** Pilot Light 240VAC	49SPL0AGG
	Green Off** Pilot Light 480VAC	49SPL0AGH
All	CPT 45VA 240/480:24VAC	KT4050
	CPT 45VA 240/480:120VAC	KT8050
	CPT 50VA 240/480:24VAC	KT4050P
	CPT 50VA 240/480:120VAC	KT8050P
	CPT 100VA 240/480:24VAC	KT4100
	CPT 100VA 240/480:120VAC	KT8100
	1 NO Aux Contact for Starter Sizes 00 - 4	49AB10
	1 NC Aux Contact for Starter Sizes 00 - 4	49AB01
	1 NO & 1 NC Aux Contact for Starter Sizes 00 - 4	49AB11

* "Off" PL requires N.C. aux contact 49AB01 for starter sizes 00-4.

** Includes NC aux contact for starter sizes 00-4.

Short Circuit Current Ratings

Fuses

Size	600V Max	600V Max
00 - 4	10kA (Class H or K)	100kA (Class R or J)
5	14kA (Class H or K)	100kA (Class R or J)
6	18kA (Class H or K)	100kA (Class R or J)
7	NA	82kA (Class R or L)
8	NA	85kA (Class R or L)

Thermal Magnetic Circuit Breaker

Size	240V Max	600V Max
00 - 3	14kA	10kA
3 1/2 - 4	10kA	10kA
5	14kA	14kA
6	18kA	18kA
7 & 8	NA	NA

NEMA Enclosure Descriptions

NEMA Type	Abbreviated Enclosure Description
1	General purpose indoor use
3/3R	Weatherproof
4	Watertight and dust tight
4X	Watertight, dust tight and corrosion resistant
7/9	Classified areas Div. 1 & Div. 2 Class I Groups C & D; Class II Groups E, F & G; Class III
12	Dust tight and drip proof for indoor use